

8 7 6 5 4 3 2 1

D
C
B
A

D
C
B
A

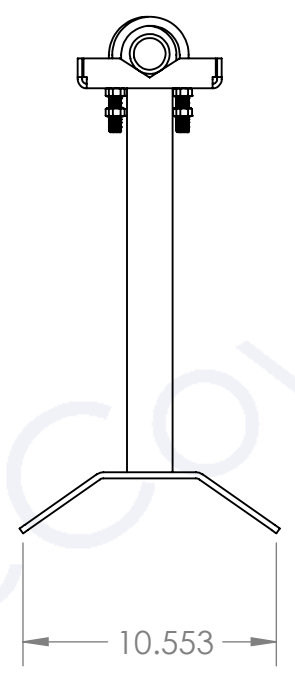
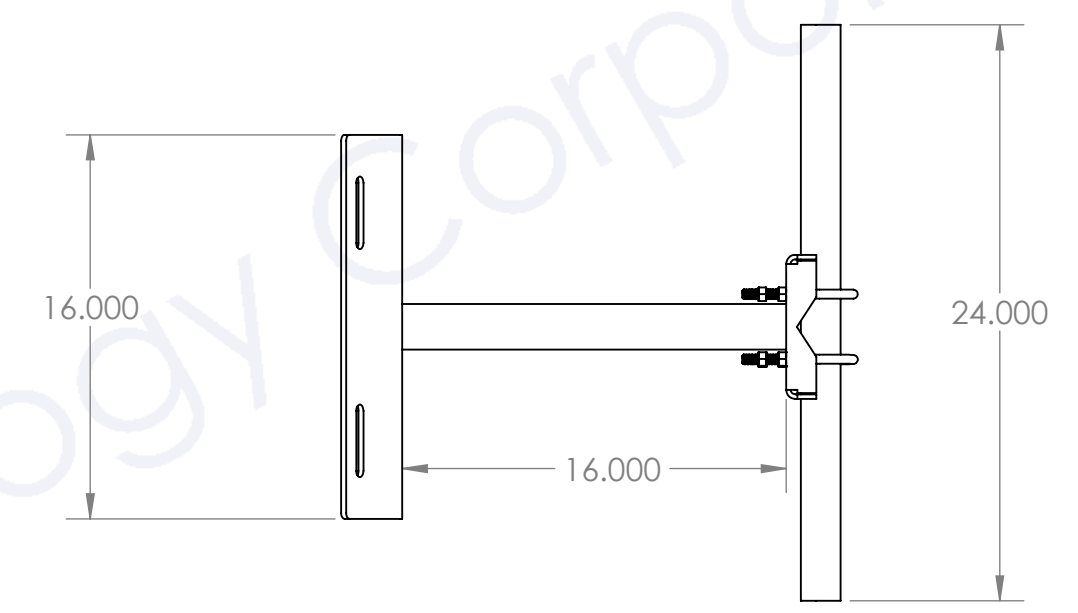
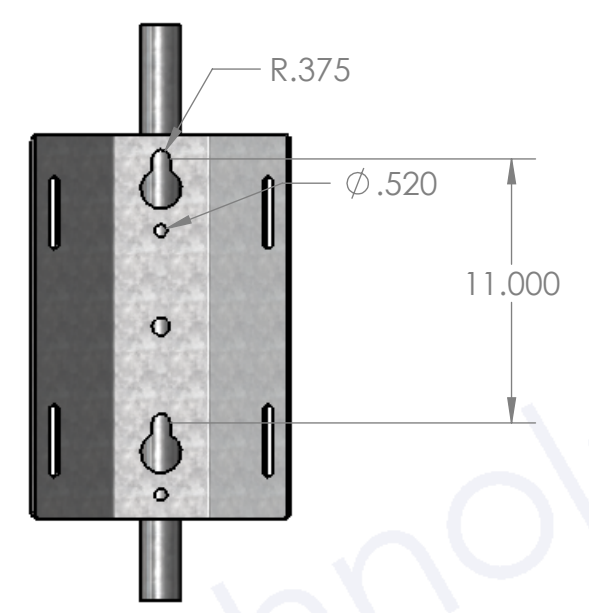
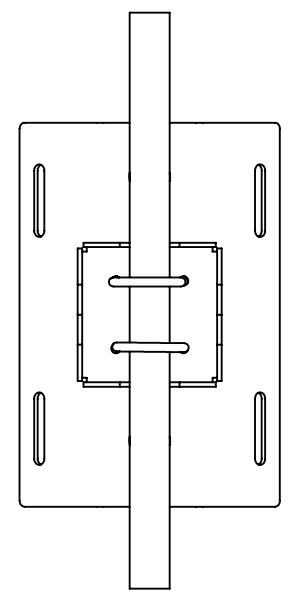

PROPRIETARY AND CONFIDENTIAL
 THE INFORMATION CONTAINED IN THIS DRAWING IS THE SOLE PROPERTY OF MCCOWN TECHNOLOGY CORP. ANY REPRODUCTION IN PART OR AS A WHOLE WITHOUT THE WRITTEN PERMISSION OF MCCOWN TECHNOLOGY CORP IS PROHIBITED.

		UNLESS OTHERWISE SPECIFIED:		NAME	DATE	801-250-9503	8400 N Hwy 36 Lakepoint Utah 84074	
		DIMENSIONS ARE IN INCHES TOLERANCES: FRACTIONAL ± ANGULAR: MACH ± BEND ± TWO PLACE DECIMAL ± THREE PLACE DECIMAL ±		DRAWN	CM			1-24-19
		INTERPRET GEOMETRIC TOLERANCING PER:		CHECKED				
		MATERIAL Carbon steel		ENG APPR.				
Weight	25 Lbs	FINISH Hot Dip Galvanized		MFG APPR.			TITLE:	
NEXT ASSY	USED ON	DO NOT SCALE DRAWING		Q.A.			SIZE	
APPLICATION				COMMENTS:			DWG. NO.	
							800-M-POL-BAND-1	
							REV	
							SCALE: 1:8	
							WEIGHT:	
							SHEET 1 OF 1	

8 7 6 5 4 3 2 1