

ITEM NO.	PART NUMBER	DESCRIPTION	QTY.
1	851-M-POL-BAND-BASE	851-M-POL-BAND-BASE	1
2	851-M-POL-BAND-1.5x16 Pipe	851-M-POL-BAND-1.5x16 Pipe	1
3	851-M-POL-BAND-END	851-M-POL-BAND-END	1
4	8862T29	051-3/8" x 2-7/16" U Bolt	2

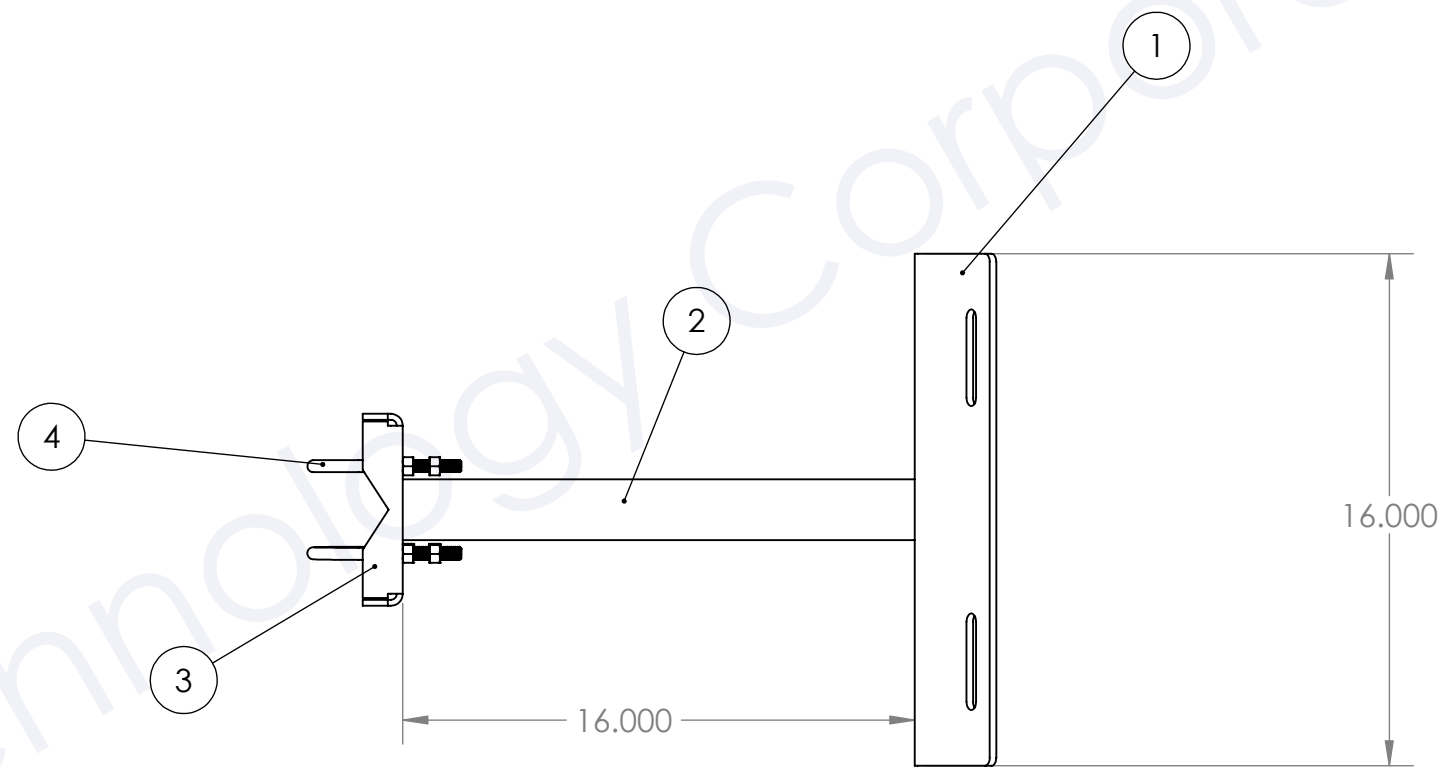

PROPRIETARY AND CONFIDENTIAL
 THE INFORMATION CONTAINED IN THIS DRAWING IS THE SOLE PROPERTY OF MCCOWN TECHNOLOGY CORP. ANY REPRODUCTION IN PART OR AS A WHOLE WITHOUT THE WRITTEN PERMISSION OF MCCOWN TECHNOLOGY CORP IS PROHIBITED.

		UNLESS OTHERWISE SPECIFIED:					
		DIMENSIONS ARE IN INCHES		DRAWN		NAME	
		TOLERANCES:		CHECKED		DATE	
		FRACTIONAL ±		ENG APPR.		1-24-19	
		ANGULAR: MACH ± BEND ±		MFG APPR.			
		TWO PLACE DECIMAL ±		Q.A.			
		THREE PLACE DECIMAL ±		COMMENTS:			
		INTERPRET GEOMETRIC TOLERANCING PER:					
Weight		20 Lbs		MATERIAL		801-250-9503	
NEXT ASSY		USED ON		FINISH		mccowntech.com	
APPLICATION		DO NOT SCALE DRAWING		Hot Dip Galvanize		8400 N Hwy 36 Lakepoint Utah 84074	
				TITLE:			
				SIZE		DWG. NO.	
				B		800-M-POL-BAND-0	
				SCALE: 1:8		WEIGHT:	
						SHEET 1 OF 1	