

ITEM NO.	PART NUMBER	DESCRIPTION	QTY.
1	Bottom Tube Mount Ears (1)	Plasma Cut	2
2	C3x4.1	Face mount channel	2
3	Top Tube Mount Ears	Plasma Cut	2
4	Clamp	This is an assembly	4
5	2.5 sch 40	Carbon Steel Pipe	1
6	3.0 sch 40 Ring	Carbon Steel Pipe	1
7	.5x13 Hex Nut	.5x13 Hex Nut	5
8	.5x13-5.0 Galv Hex Bolt	.5x13-5.0 Galv Hex Bolt	1
9	.5x 5.3 gap Bolt Stack	Same bolt assy as M-TOW	4
10	.5x13-2.0 Galv Hex Bolt	.5x12-2 Galv Hex Bolt	2

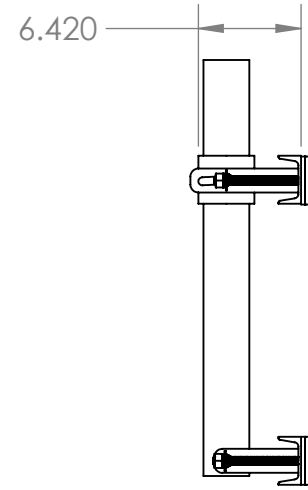

Clamp bar slides over tower legs an other irregular features clamping to almost anything.

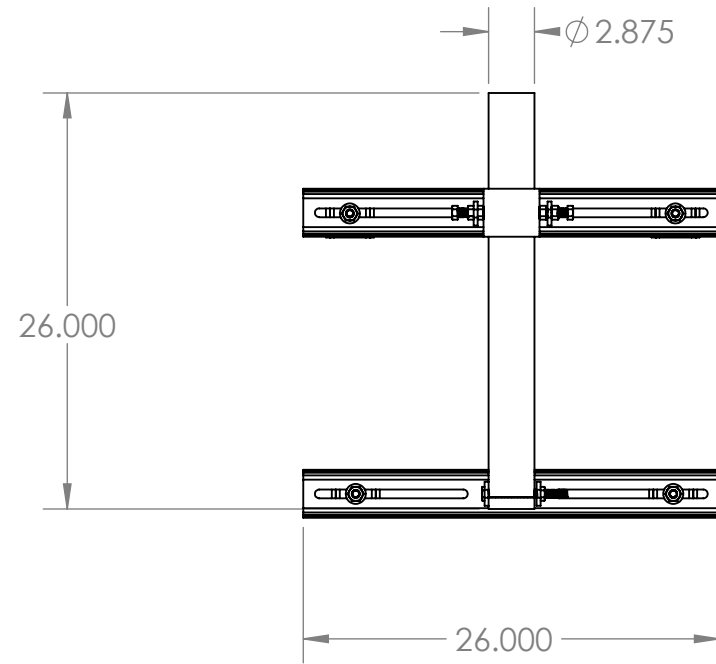
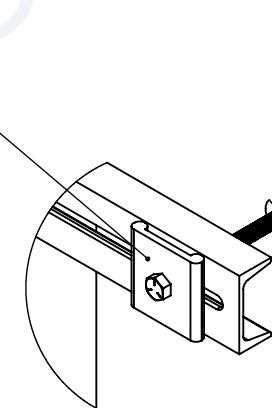
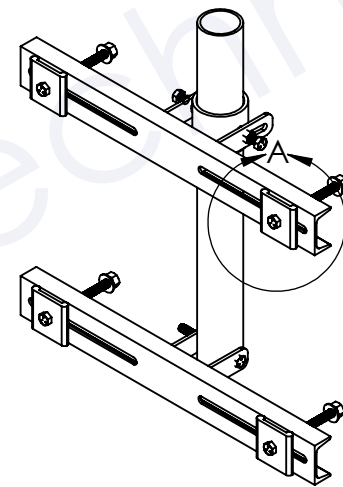
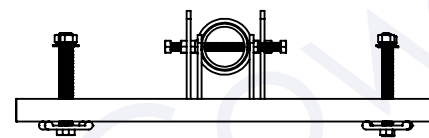

DETAIL A
SCALE 1 : 6

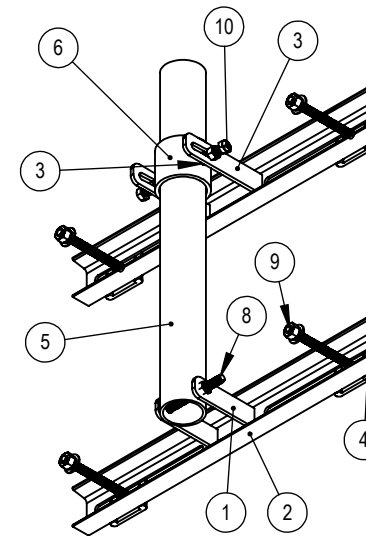

PROPRIETARY AND CONFIDENTIAL
THE INFORMATION CONTAINED IN THIS DRAWING IS THE SOLE PROPERTY OF MCCOWN TECHNOLOGY CORP. ANY REPRODUCTION IN PART OR AS A WHOLE WITHOUT THE WRITTEN PERMISSION OF MCCOWN TECHNOLOGY CORP IS PROHIBITED.

		UNLESS OTHERWISE SPECIFIED:		NAME	DATE	 8400 N Hwy 36 Lakepoint Utah 84074	
		DIMENSIONS ARE IN INCHES		DRAWN	CM		2-2-17
		TOLERANCES:		CHECKED			
		FRACTIONAL ±		ENG APPR.			
		ANGULAR: MACH ± BEND ±		MFG APPR.			
		TWO PLACE DECIMAL ±		Q.A.			
		THREE PLACE DECIMAL ±		COMMENTS:			
		INTERPRET GEOMETRIC TOLERANCING PER:					
		MATERIAL					
		Carbon Steel					
		FINISH					
		Hot Dipped Galvanize					
NEXT ASSY	USED ON						
APPLICATION		DO NOT SCALE DRAWING					
				TITLE:			
				M-TOW-FACE-26-26 Reference Drawing			
SIZE		DWG. NO.		REV			
B				B			
SCALE: 1:12 WEIGHT: 40#				SHEET 1 OF 1			