

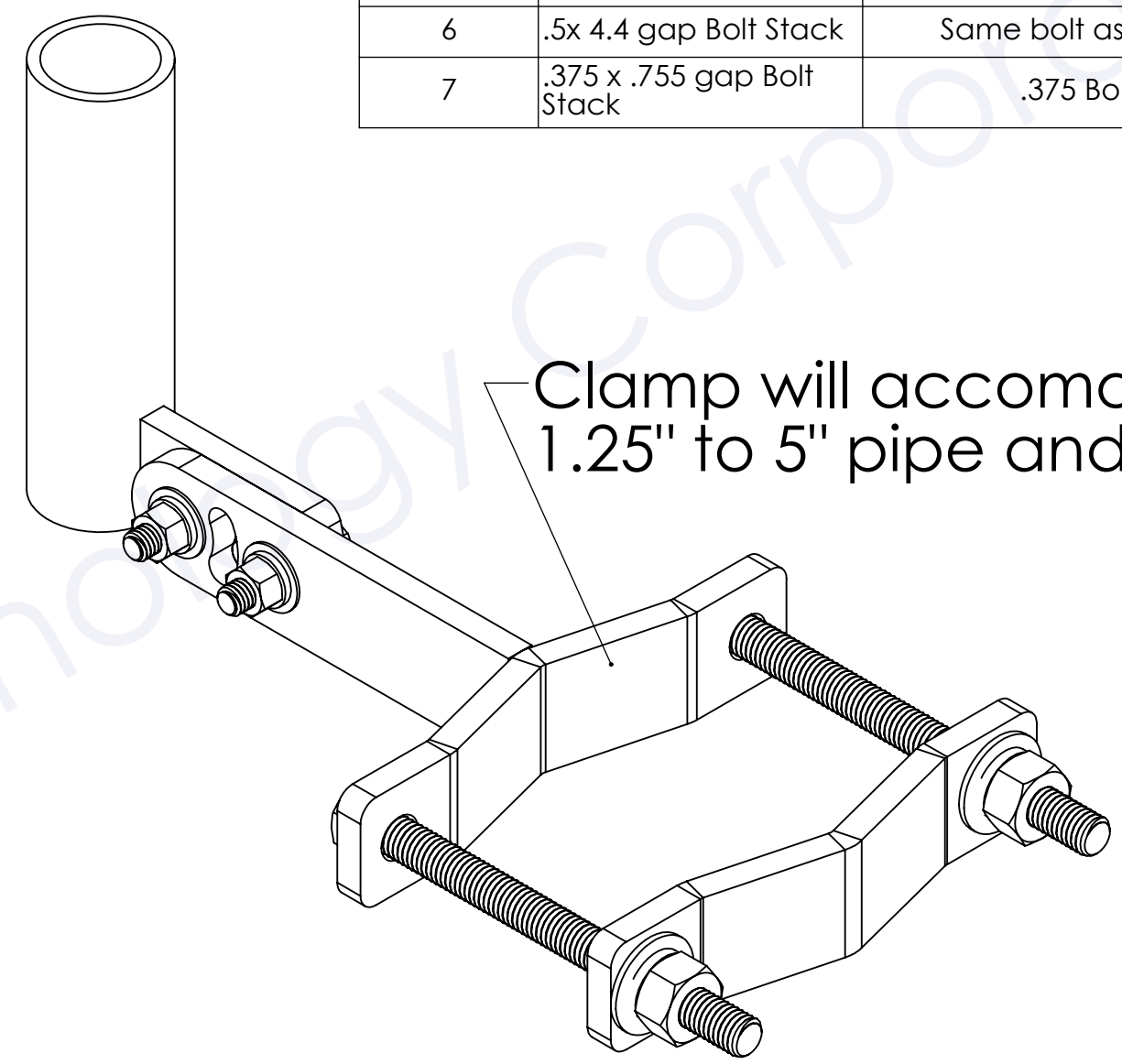

8 7 6 5 4 3 2 1

ITEM NO.	PART NUMBER	DESCRIPTION	QTY.
1	851-150-.375-TCLAMP	Clamp 5"	1
2	1.25 x 6 pipe	1.66 OD Pipe	1
3	850-M-TOW-LSB	850-M-TOW-LSB	1
4	851-150-.375-SF	Short F Bar	1
5	850-M-TOW-FT Rev B	Clamp 5"	1
6	.5x 4.4 gap Bolt Stack	Same bolt assy as M-TOW	2
7	.375 x .755 gap Bolt Stack	.375 Bolt Stack	2

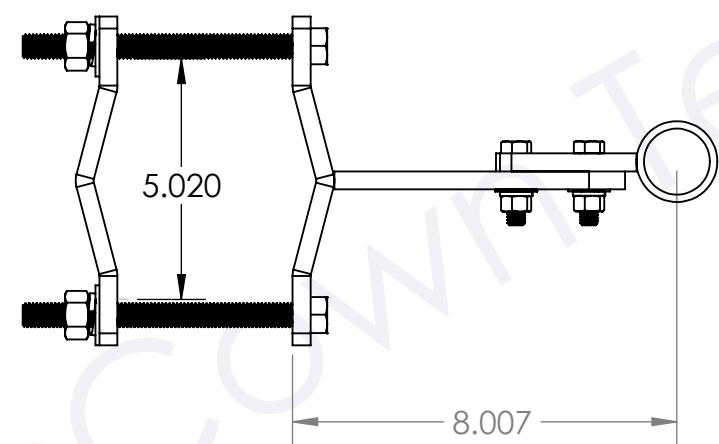
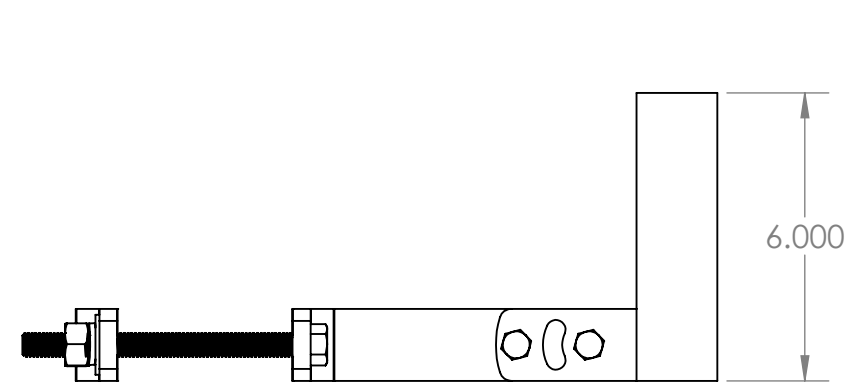

PROPRIETARY AND CONFIDENTIAL
 THE INFORMATION CONTAINED IN THIS DRAWING IS THE SOLE PROPERTY OF MCCOWN TECHNOLOGY CORP. ANY REPRODUCTION IN PART OR AS A WHOLE WITHOUT THE WRITTEN PERMISSION OF MCCOWN TECHNOLOGY CORP IS PROHIBITED.

		UNLESS OTHERWISE SPECIFIED:		NAME	DATE
		DIMENSIONS ARE IN INCHES		DRAWN	CM
		TOLERANCES:		CHECKED	1-30-17
		FRACTIONAL ±		ENG APPR.	
		ANGULAR: MACH ± BEND ±		MFG APPR.	
		TWO PLACE DECIMAL ±		Q.A.	
		THREE PLACE DECIMAL ±		COMMENTS:	
		INTERPRET GEOMETRIC TOLERANCING PER:			
		MATERIAL			
		Carbon Steel			
		FINISH			
		Hot Dip Galv			
NEXT ASSY	USED ON	APPLICATION		DO NOT SCALE DRAWING	

801-250-9503				8400 N Hwy 36 Lakepoint Utah 84074	
TITLE: M-TOW-6 Reference Dwg					
SIZE	DWG. NO.			REV	
B				B	
SCALE: 1:4	WEIGHT:			SHEET 1 OF 1	

8 7 6 5 4 3 2 1